

H HYDRO
 12 whirlpool jets
 12 vodních trysek

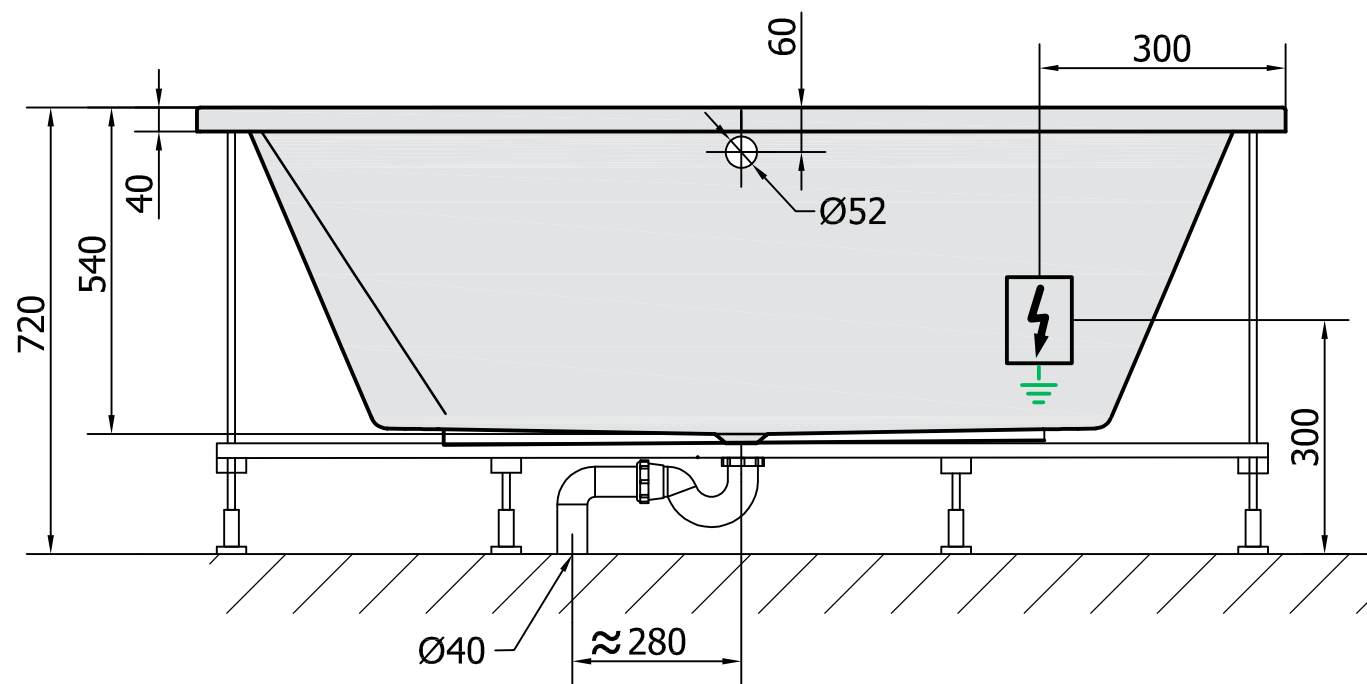

Electric cable 3x2,5mm²
 Length 2m from the wall
L
 Elektrický kabel 3x2,5mm²
 Délka kabelu ze zdi 2m

Electrical Characteristic:
 Tension: 220-230V/50hz
 Max. power consumption: 800W
 Electric protection: residual-current device 30mA

Elektrické vlastnosti:
 Napětí: 220-230V/50hz
 Max. spotřeba: 800W
 Elektrické jištění: proudový chránič 30mA

VOLUME 580L

Kreslil vs	Kontroloval	Schválil	Datum	Datum	
polysan 		13611H WHIRLPOOL BATH TUB			List
DUPLA 180x120				1 / 1	