

ERGO STORAGE

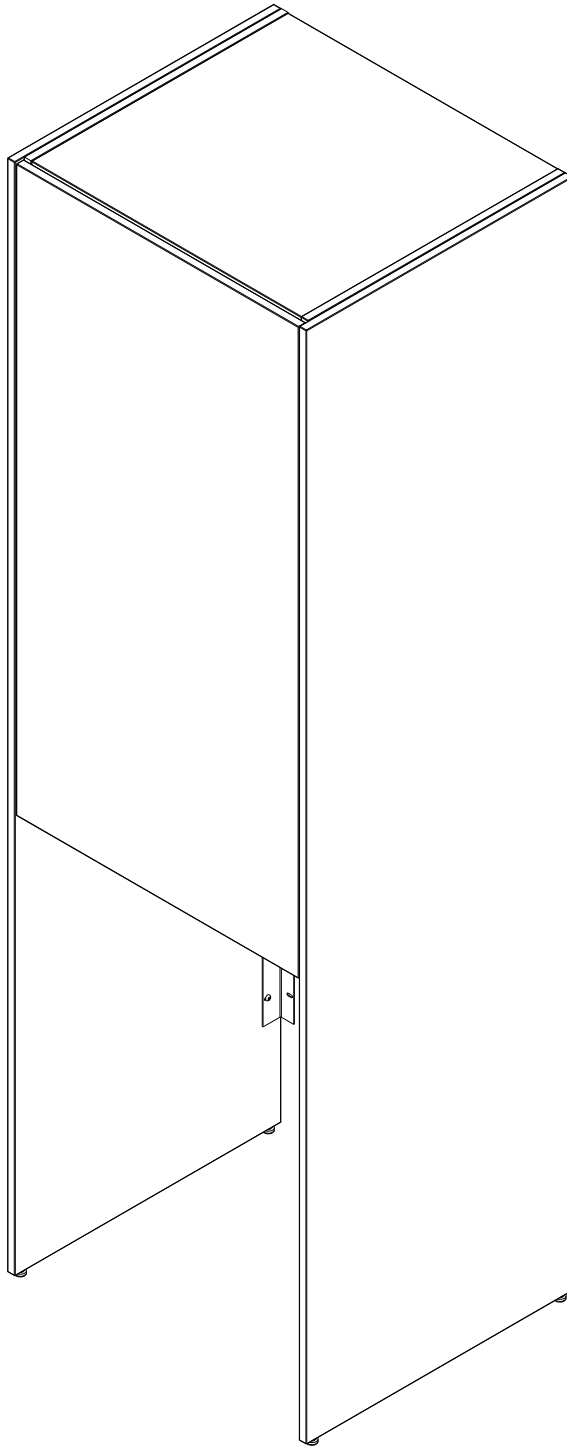

Asennusohje | Monteringsanvisningar | Assembly Instructions

(FI) Sisällysluettelo

Toimitussisältö..... 2
Irtosivujen ja saranan
aluslevyjien kiinnitys 3
Kiinnityspisteet..... 4
Oven asennus..... 5
Oven poisto..... 6
Oven säätö..... 7

(SE) Innehåll

Leveransinnehåll 2
Montering av frisidor och
gångjärnsbrickor 4
Montering av lucka..... 5
Ta bort lucka 6
Justering av lucka 7

(GB) Table of Contents

Package Contents..... 2
Installation side panels and
hinge washers..... 3
Attachment Points..... 4
Installing the door 5
Removing the door..... 6
Adjusting the door..... 7

Toimitussisältö | Leveransinnehåll | Package Contents

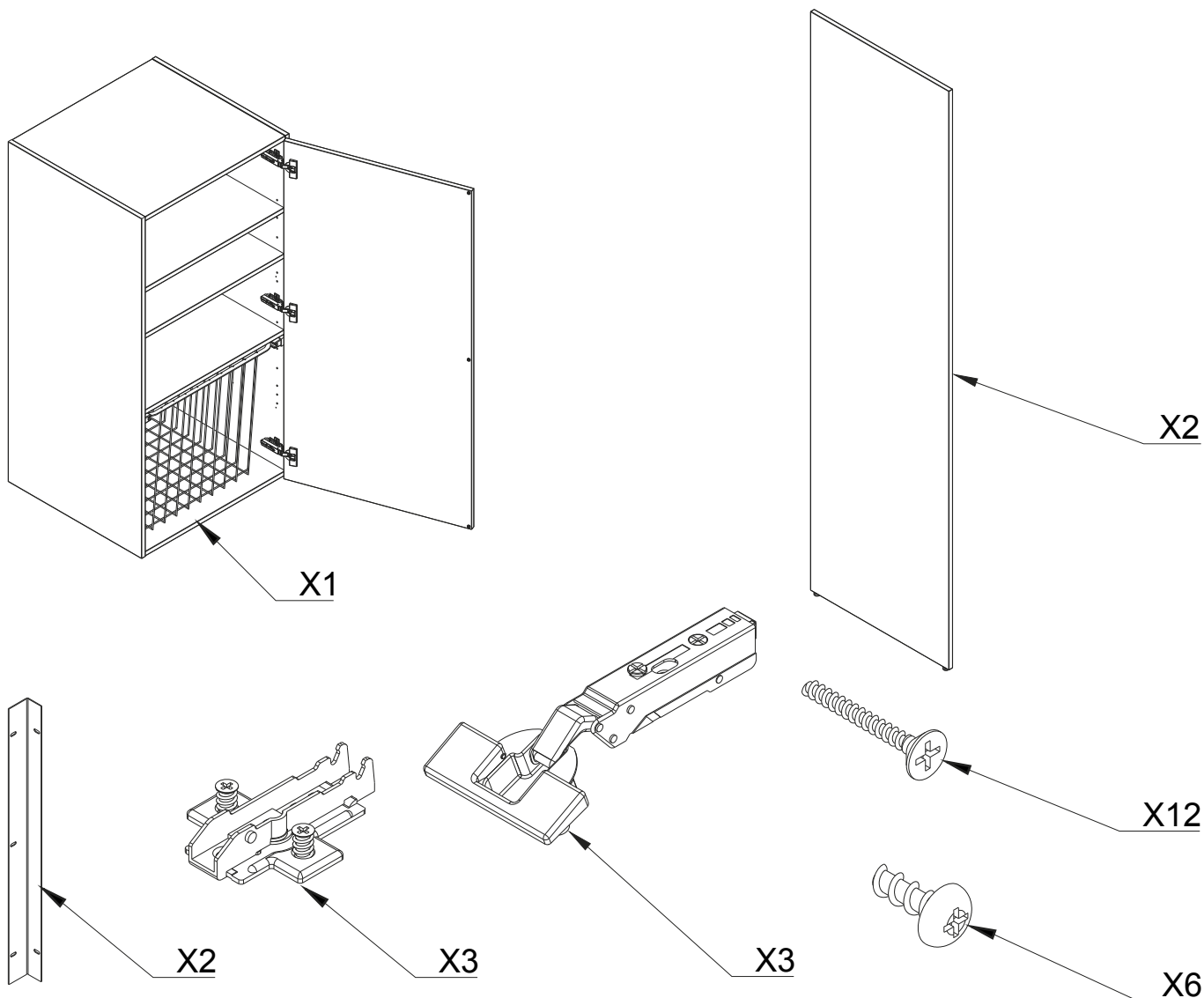

Irtozivujen ja saranan aluslevyjen kiinnitys |
Montering av frisdor och gångjärnsbrickor | Installation side panels and hinge washers

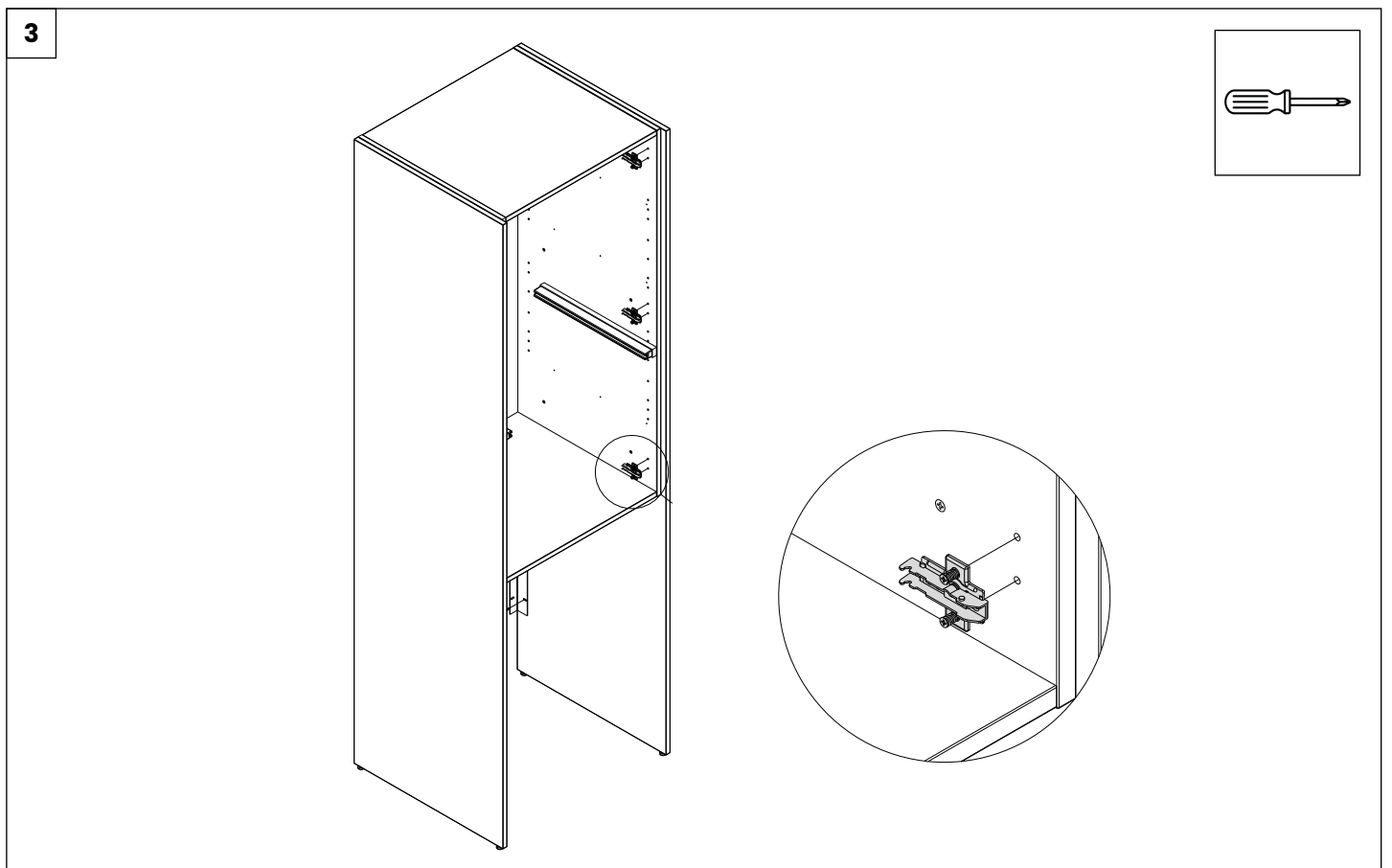
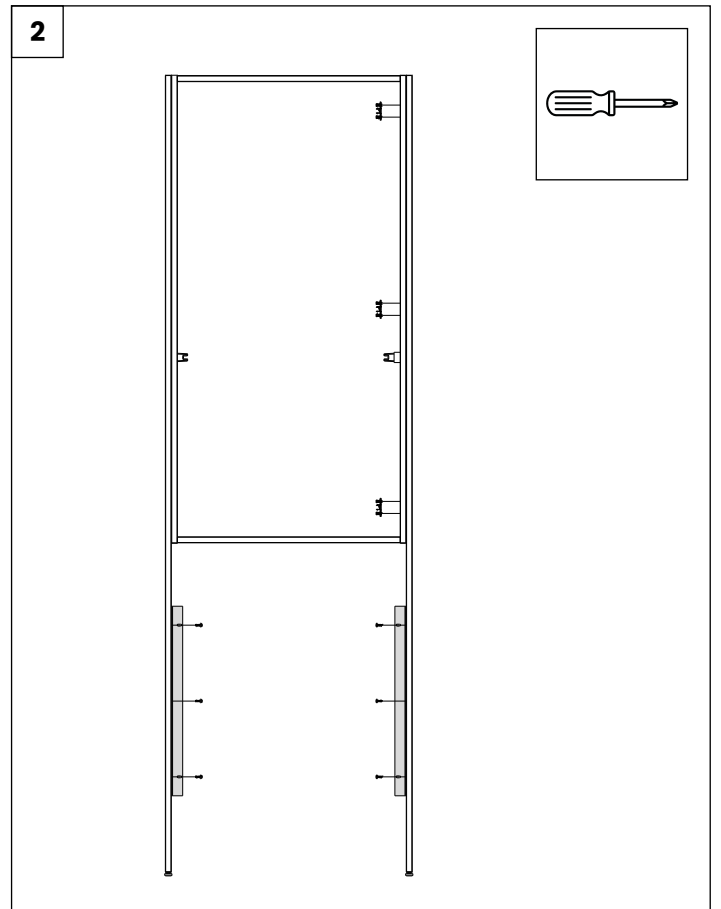
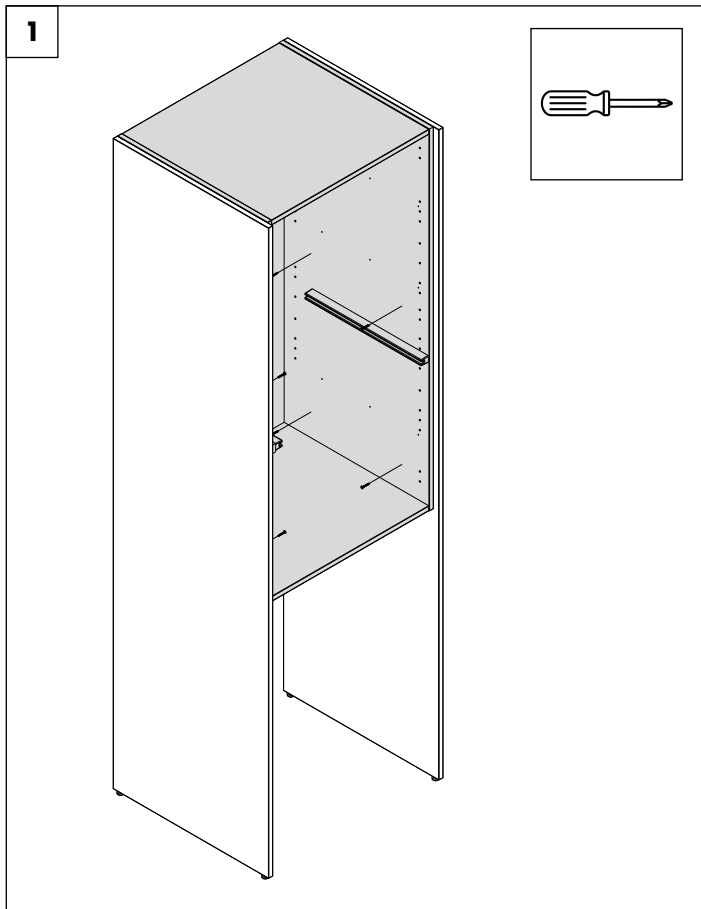

4

- X** = Kiinnityspisteet
- X** = Fästpunkter
- X** = Attachment points

Tarkista suoruus ja kiinnitä seinään.
 Kontrollera att den är rak och fäst den på väggen.
 Check for straightness and attach to the wall.

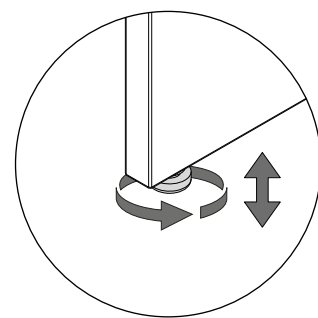
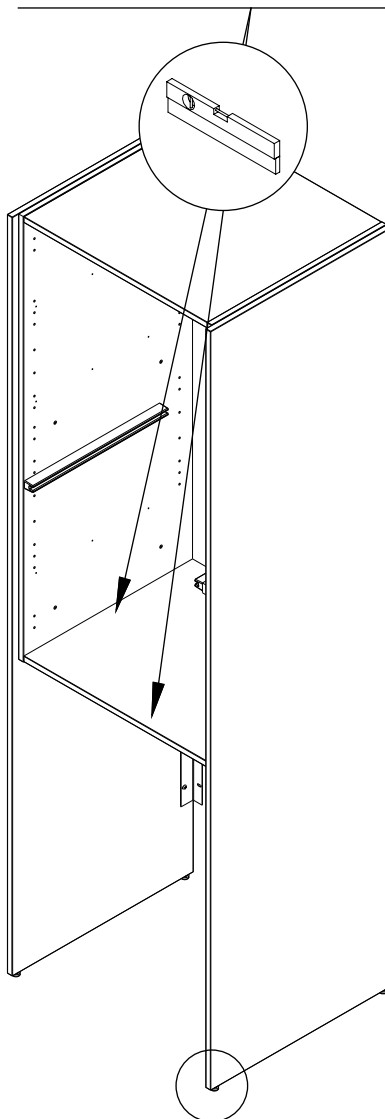
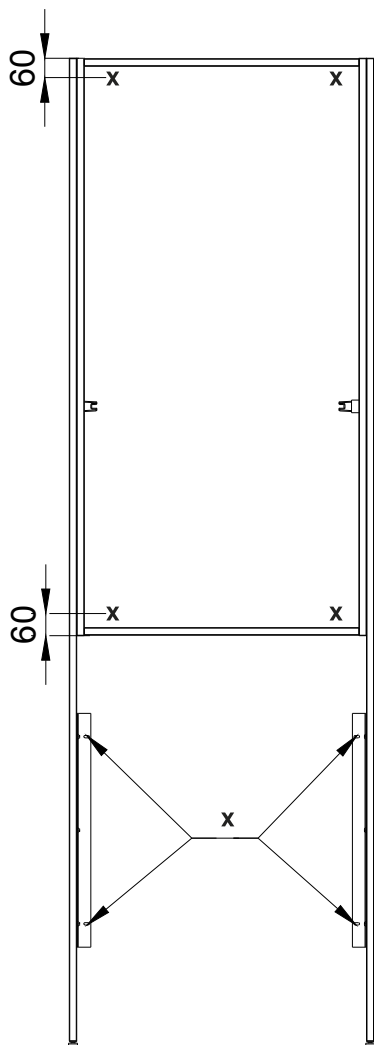
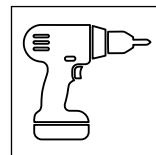

Jos seinän kosteuseriste läpäistään, on kohta tiivistettävä sopivalla massalla. Kiinnitykseen käytettävät kiinnikkeet ja menetelmät vaihtelevat seinämateriaalista riippuen (poraus, tulpat ym.).”

Om väggens fuktspärr genombrysts måste genomföringen tätas med en lämplig massa. De fästen och metoder som används för montering varierar beroende på väggmaterialet (borring, pluggar osv.).

If the wall's moisture barrier is penetrated, the opening must be sealed with an appropriate sealant. The mounting brackets and methods used will vary depending on the wall material (drilling, plugs, etc.).

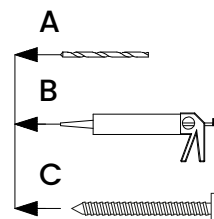
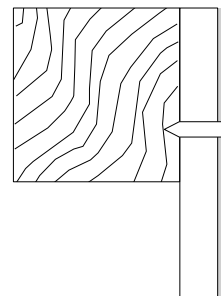
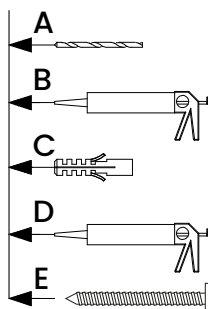
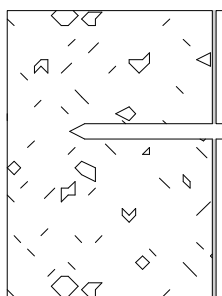

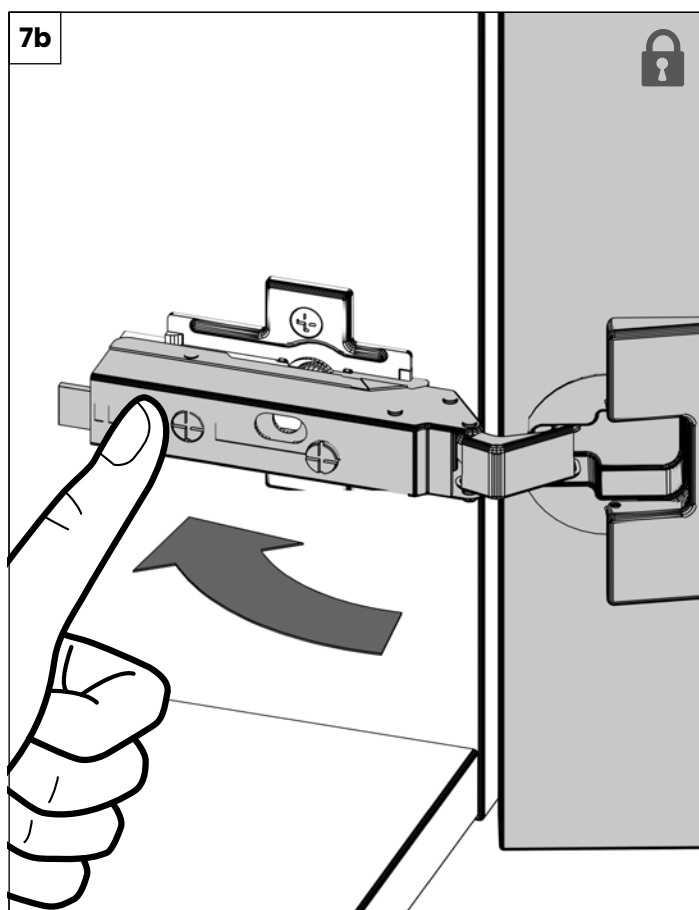
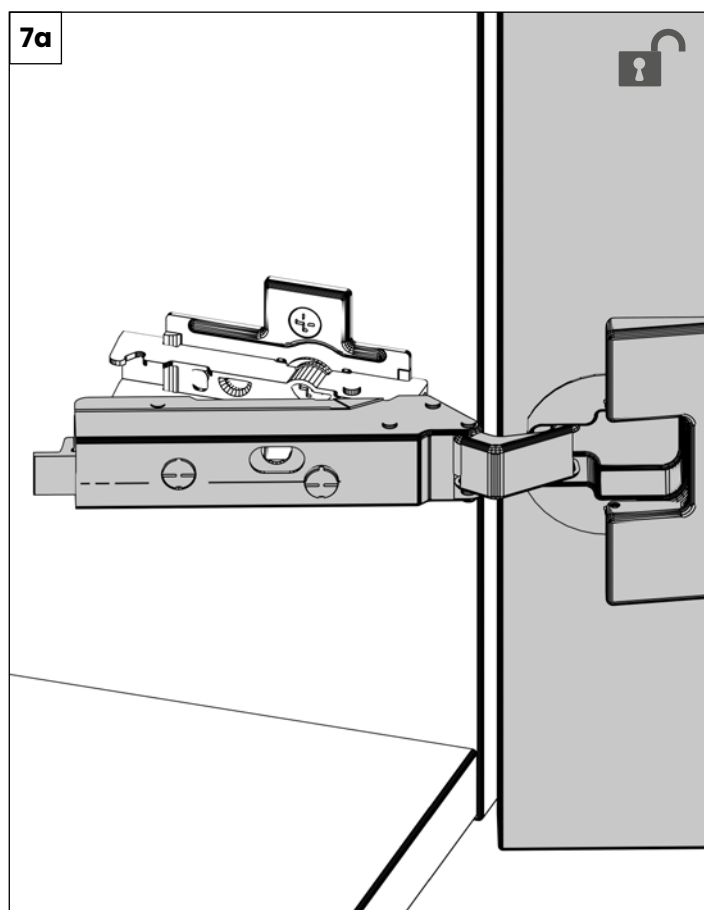
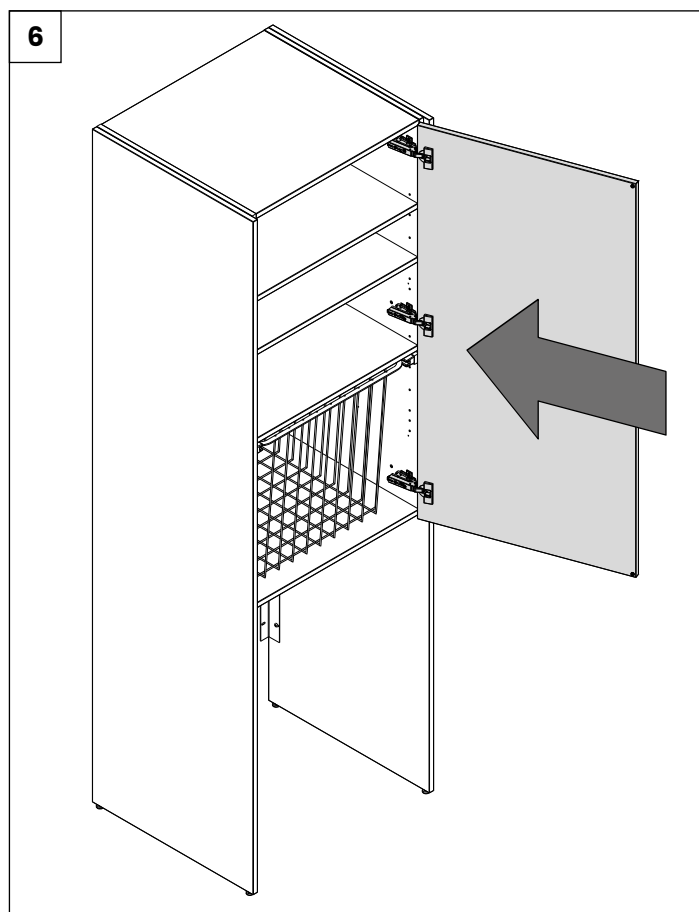
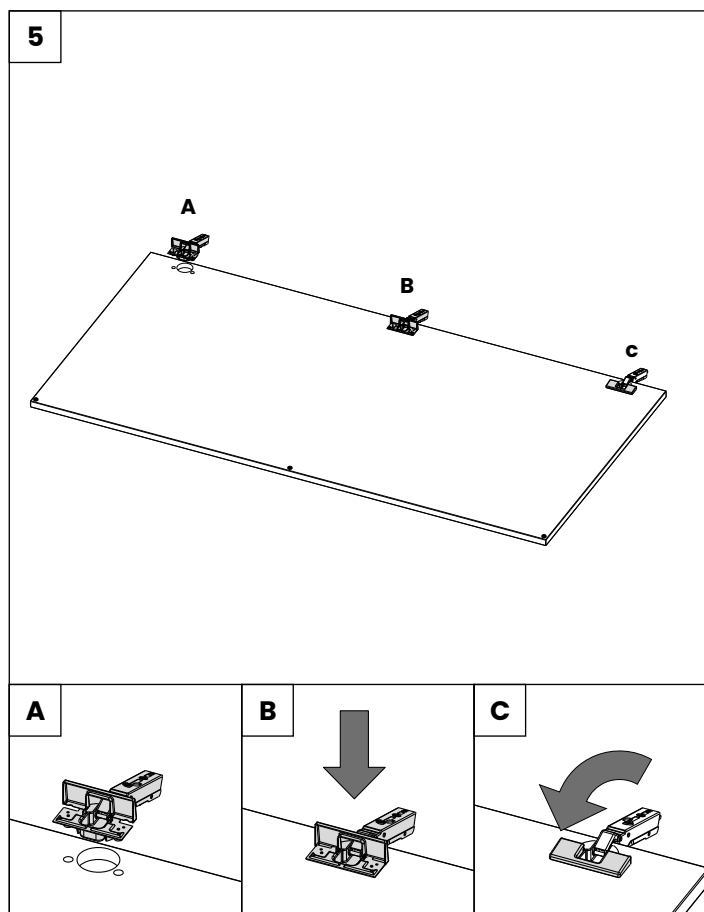

Oven poisto | Ta bort lucka | Removing the door

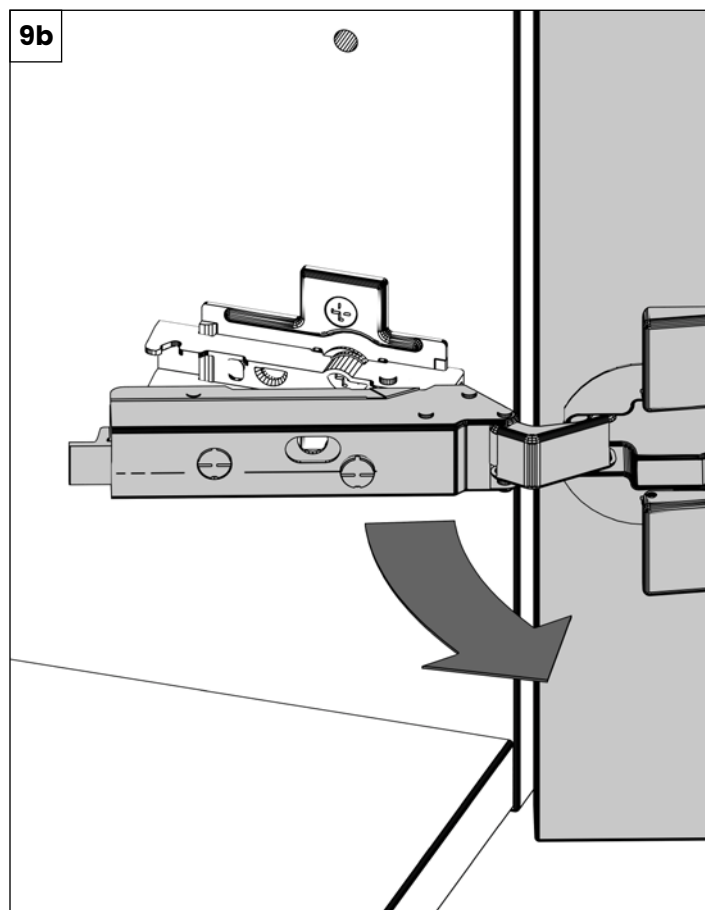
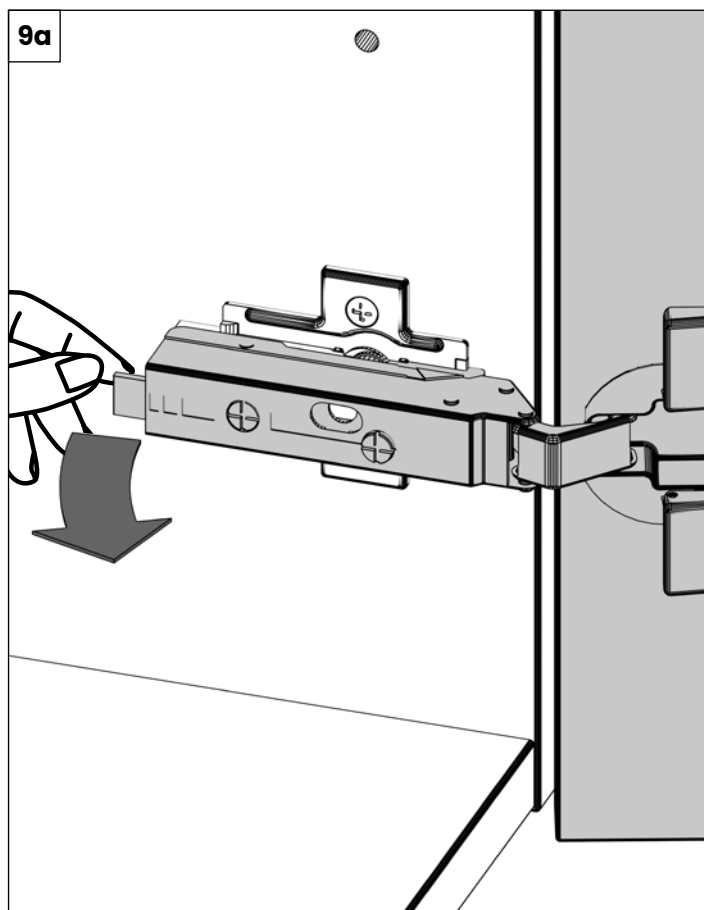
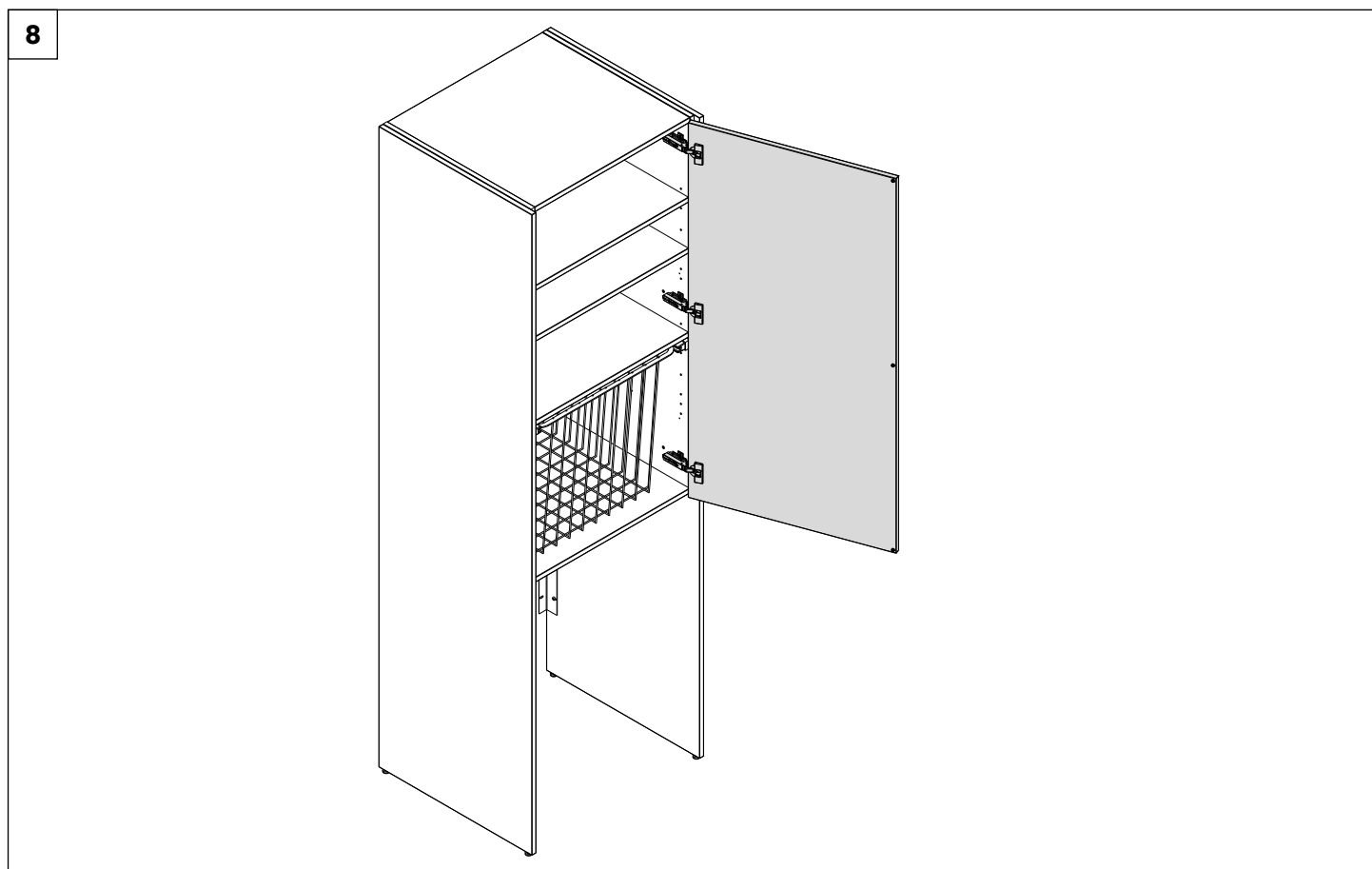

Oven säätö | Justering av lucka | Adjusting the door

Saranan vaimennuksen säätö | Verktygsfri justering av spjäll | Tool-free damper adjustment

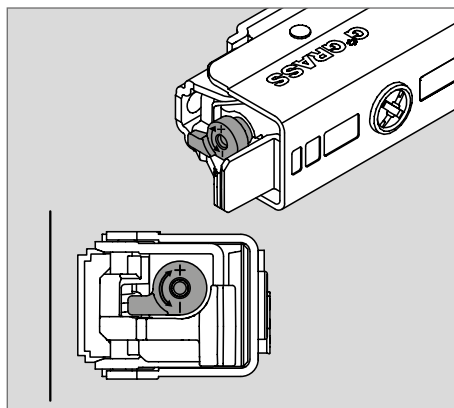

Kevyt taso
Lätt justering
Light level

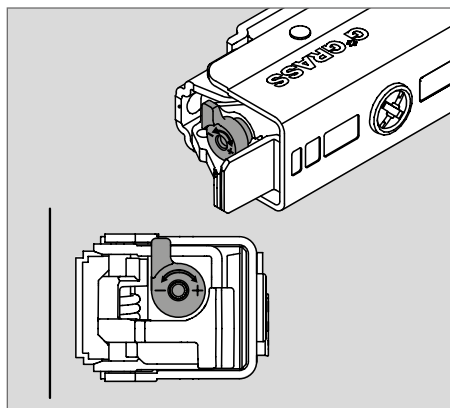

Keskitaso (tehdasasetus)
Medium justering (fabriksinställning)
Medium level (factory setting)

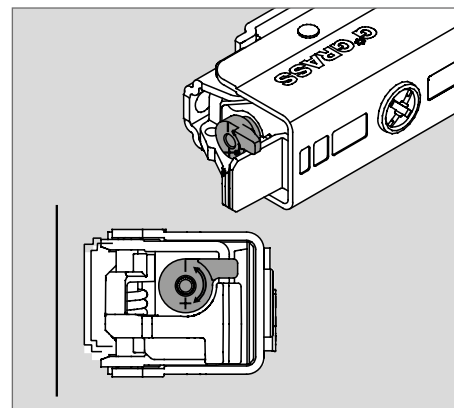

Raskas taso
Tung justering
Heavy level

Oven säädöt | Justeringar av luckan | Adjustments to the door

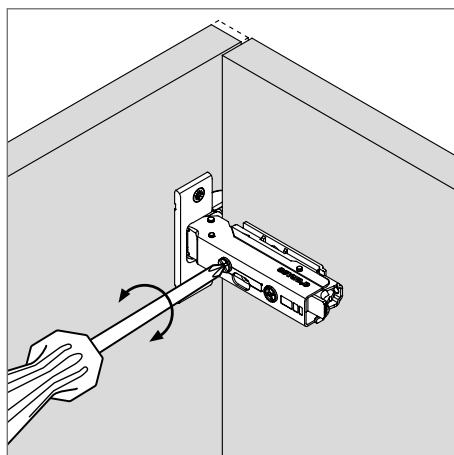

Sivuttaissäätö +/- 2 mm
Sidojustering +/- 2 mm
Side adjustment +/- 2 mm

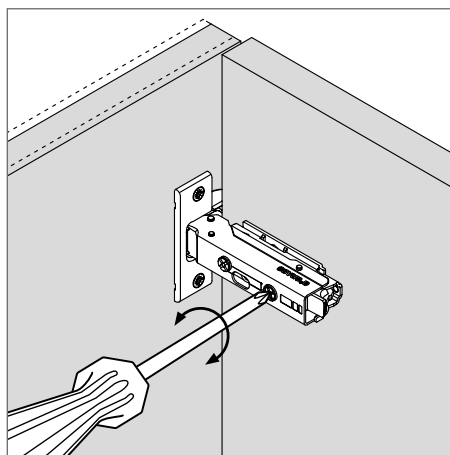

Syvyyden säätö +3/-2 mm
Djupjustering +3/-2 mm
Depth adjustment +3/-2 mm

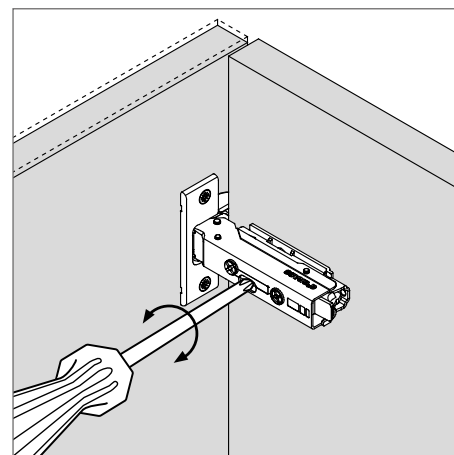

Korkeuden säätö +/- 2 mm
Höjdjustering +/- 2 mm
Height adjustment +/- 2 mm

